

**ATRA ACE**  
Model **CLA-2720**



**NITTO**  
MODEL **CLA-2720**  
DC 18 V  
430 min<sup>-1</sup>

**WARNING**  
Read the instruction manual before use.

**LOAD**

Cutter diameter	Plate thickness
JETROACH 12-27 mm dia.	6-12 mm
HI-BROACH 12-25 mm dia.	6-20 mm
HI-BROACH 10-27 mm dia.	6-12 mm
2-8-A 10-27 mm dia.	6-20 mm

NITTO KOHKI CO., LTD.  
Oma-ku Tokyo  
148-8565 Japan  
MADE IN JAPAN

**WARNING**  
Do not touch the cutter or other rotating parts of the machine after the trigger pack has been inserted.



**ATRA ACE**  
Model **CORDLESS MODEL**  
**CLA-2720**



Portable Magnetic Base Drilling Machine

**CORDLESS**

**ATRA**

## HANDY

**Total Weight Just 7 kg**

Weight reduced by utilising a moulded plastic Housing

**Powered by a Battery**

It makes it possible to drill holes anywhere

## TOP-LEVEL SAFETY

**Highly Sensitive Sensor Equipped**

Side Slip and Inclination detected by a built-in sensor

**Self-check Function**

The machine checks for faults itself

Cordless and compact body

**Powered by a Battery !!**

Suitable for high or narrow or hard to access areas.

## HIGHLY ADVANCED ENERGY-SAVING

**Magnetic Force Control Function**

The magnet force is automatically reduced when the drill is not running

**Soft Start Function**

The large electric current on start-up is prevented by starting the electric drill gently

**Automatic Drill Stop and Warning Function**

Unnecessary operations are eliminated

Hole Cutting Capacity :  
Hole Diameter

**12 to 27mm**



Actual Size **293 mm**

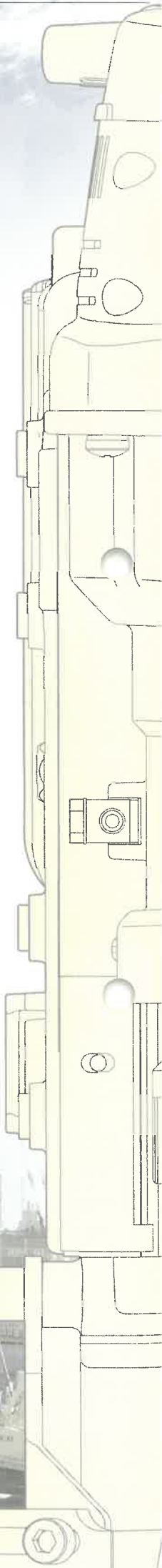

**Li-ion**

Lithium-ion batteries are required to be recycled; never discard a lithium-ion battery in the waste. Please contact your local sales office or community recycling program for information on properly disposing of lithium-ion batteries.

## [ LED INDICATION (BATTERY & MOTOR) ]

The high luminance LED lamp will give full support to your drilling!

### ● LED INDICATION / The battery level can be confirmed at a glance.

BATTERY LEVEL INDICATION	VOLTAGE LEVEL			
	<p>RED BLINKING CONTINUOUS</p> <p>BATTERY LEVEL LOW</p>	<p>RED 3 TIMES*</p> <p>REQUIRE CHARGING</p>	<p>YELLOW 3 TIMES*</p> <p>PARTIALLY CHARGED</p>	<p>GREEN 3 TIMES*</p> <p>FULL</p>

\*After the lamp flashes 3 times with the color according to the battery level, the lamp turns green.

LED Indication



### ● LED INDICATION / The load on the Motor can be monitored while drilling.

MOTOR LOAD INDICATION	ELECTRIC CURRENT OF THE ELECTRIC DRILL			
	<p>GREEN</p> <p>LIGHT LOAD</p>	<p>YELLOW</p> <p>MEDIUM LOAD</p>	<p>RED</p> <p>OVERLOAD</p>	<p>RED BLINKING</p> <p>MOTOR STOPPED BY OVERLOAD</p>

Caution! If the excessive load is kept applied on the drill, the Motor will come to a full stop to protect the Motor and the operator.

SLIDE SLIP DETECTION	<p>(BLUE) BLINKING</p> <p>When a slide slip is detected, the blue lamp will flash and the Motor will stop automatically.</p> <p><b>SAFETY</b></p>
"NO LOAD" DETECTION	<p>(GREEN) BLINKING</p> <p>While the electric drill is running, if no load is applied for 7 seconds, the green lamp will flash. After another 3 seconds without load, the electric drill will be stopped automatically.</p> <p><b>ENERGY-SAVING</b></p>
MOTOR NOT ACTIVATED IN TIME	<p>(GREEN) BLINKING</p> <p>After the Magnet switch is turned on, if the Motor switch is not turned on within 10 seconds, the green lamp will flash.</p>

## [ Battery Pack & Battery Charger ]



## [ Adjustment of

### Drilling Position ]



### [ Feed Handle Location ]

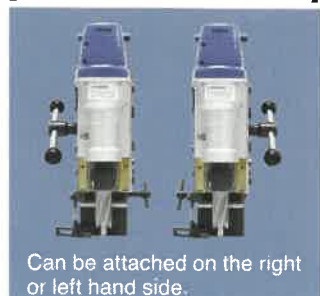

## [ Optional Items ]





### [ Combination of Pilot Pins & Broach Cutters ]

Size	Part No.			
	PILOT PIN 06025(C1) Part No.TK01167	PILOT PIN 08025(A1) Part No.TJ12696	PILOT PIN 06025(C1) Part No.TK01167	PILOT PIN08035(A2) Part No.TJ15859
	One-touch Type HI-BROACH		One-touch Type JETBROACH	
Diameter	Depth 25 mm		Depth 25 mm	Depth 35 mm
12	TK00698		TK01148	
13	TK00699		TK01149	
14	TK00700		TK01150	
15	TK00701		TK01151	
16	TK00702		TK01152	
17	TK00703		TK01153	
17.5		TK00335		TK00301
18		TK00336		TK00302
18.5				TK00303
19		TK00337		TK00304
19.5		TK00338		TK00305
20		TK00339		TK00306
20.5				TK00307
21		TK00340		TK00308
21.5		TK00341		TK00309
22		TK00342		TK00310
22.5		TK00343		TK00311
23		TK00344		TK00312
23.5		TK00345		TK00313
24		TK00346		TK00314
24.5		TK00347		TK00315
25		TK00348		TK00316
26		TK00349		TK00317
26.5		TK00350		TK00318
27		TK00351		TK00319

### [ Optional Items ]

Cutting Oil  
2L Can (Blue)  
Part No. TB01507



Supporting  
Magnet Ass'y  
Part No. TB04374



Battery Charger \*  
Part No. TB09825  
(AUSTRALIA : Part No. TB09806)



Battery Pack \*  
Part No. TB09824



Guard \*  
Part No. TQ14333



\*Included in standard accessories.

### [ Specifications ]

Model (Atra Main Unit)	<b>CLA-2720</b>	
Voltage	18 V	
Battery Pack (Lithium-ion Battery)	NBL18006 (18 V 4.0 Ah)	
No Load Speed	min <sup>-1</sup> 430	
	Hole Diameter	Plate Thickness
One-touch Type JETBROACH	mm 12 to 17	6 to 12
One-touch Type HI-BROACH	mm 17.5 to 27	6 to 20
	mm 12 to 15	6 to 12
	mm 16 to 27	6 to 20
Magnet Holding Power	N(kgf) 5,500(561)	
Magnet Dimensions	mm 65 x 126	
Adjustment range of drilling position	Right and Left	10 mm
	Back and forth	10 mm
Mass (Weight)	kg 7*	
Standard Accessories	<ul style="list-style-type: none"> <li>● Lashing Belt BLC002R-015 : 1pc.</li> <li>● Carry Case Ass'y : 1set</li> <li>● Cutting Oil 0.5L Ass'y : 1set</li> <li>● Jet oiler NO.3013 : 1pc.</li> <li>● Tube 4x7 : 1m</li> <li>● Battery Charger : 1pc.</li> <li>● Battery Pack 18V NBL18006 : 2pcs.</li> <li>● Guard : 1pc.</li> <li>● Handle Ass'y : 1set</li> <li>● Blade : 1pc.</li> <li>● Hex. Socket Head Cap Screw 5x12 : 1pc.</li> <li>● Hex. Socket Head Set Screw 8x28 : 1pc.</li> <li>● Hex. Socket Screw Key 3 : 1pc.</li> <li>● Hex. Socket Screw Key 4 : 1pc.</li> <li>● Spanner 8x10 : 1pc.</li> </ul>	

\* Including Battery Pack and Feed Handle.

Model (Battery Pack)	<b>NC14435</b>
Power Source	220 - 240 V AC
Charging Time	90 min*
Chargeable battery pack	NBL18006(18 V 4.0 Ah)

\* In case of a full charge from an empty battery.  
However, it can be charged up to 95% in 45 min.

### [ Dimensions ]

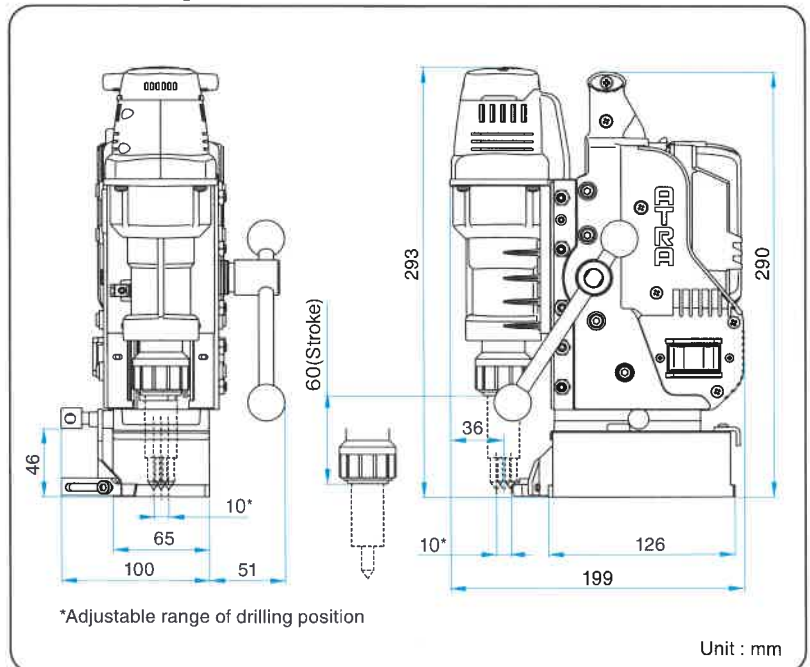

### Head Office

9-4, Nakaikegami 2-chome, Ohta-ku, Tokyo 146-8555 Japan  
Tel : +81-3-3755-1111 Fax : +81-3-3753-8791  
E-mail : overseas@nitto-kohki.co.jp

Web [www.nitto-kohki.co.jp/e](http://www.nitto-kohki.co.jp/e)

DISTRIBUTED BY



## HAJO TOOL

PROFESSIONELT SPECIALVÆRKTØJ

Vejlegårdsvej 65 B • DK-2665 Vallensbæk  
Telefon +45 4444 2400 • Fax +45 4444 0833  
[www.hajo.dk](http://www.hajo.dk) • [hajo@hajo.dk](mailto:hajo@hajo.dk)



By reusing 2.34 kg of aluminum plate used during the printing process, Nitto Kohki has reduced CO<sub>2</sub> emissions by 23.81 kg.



Smart Energy Co., Ltd. examined this numerical value and confirmed it.  
NITTO KOHKI CO., LTD. participates in an Indonesian reforestation project with print by MCP.